

BNZF bushing

Self-lubricating, flanged.

**Self-lubricating Bushings:**

A self-lubricating sintered bushing is a metallic component with high porosity (20-25% in volume), impregnated with a mineral based lubricant oil (non FDA/NSF). The oil contained in the porosity provides a constant lubrication between bearing and shaft, so the system does not need any additional external lubricant. Self-lubrication allows this type of sliding bushing to work under hydrodynamic conditions, resulting in a very low friction coefficient.

Self-lubricating sintered bushings have some advantages compared to other types of dry sliding bushings:

- Reliability. The constant oil presence eliminates the risk of seizure, and allows the bearing to work during thousands of hours without wear.
- Economy. Maintenance-free, no need for lubricants.
- Temperature range: -20°C to +110°C
- Performance. Able to work under loads of up to 10 N/mm², and speeds up to 5 m/s. The maximum working PV is in the range of 30 psi·in/s, but it can be surpassed in special cases. The dimensional precision is very high (up to IT 5 in diameter), and produce extremely low noise.

Mounting:

Shaft hardness:	> 20 HRC
Surface roughness:	< 0,3 Ra
Shaft tolerance:	f7/g6
Housing tolerance:	H7

Typical tolerance of the inside bore after mounting:

Flanged bushing	H8
-----------------	----

See the following pages for dimensions.

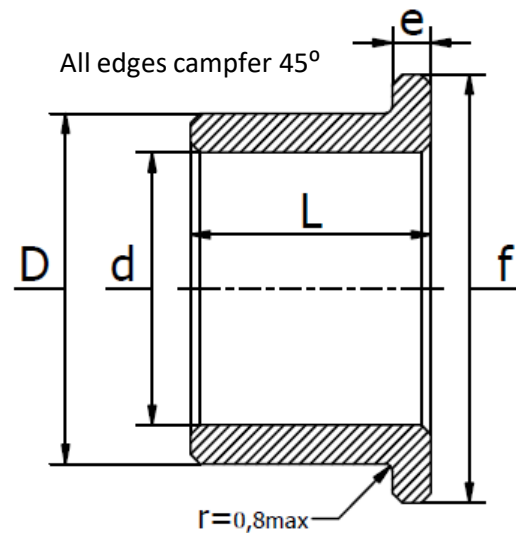

Diameter before fitting						
d (mm)	tolerance G8 (μm)	D (mm)	tolerance s8 (μm)	F (mm)	e (mm)	L = Available lengths, tolerance js13
3	+16 / +2	6	+37 / +19	9	1,5	4 - 5 - 6 - 10
4	+22 / +4	8	+45 / +23	12	2	4 - 5 - 8 - 10 - 12
6	+22 / +4	10	+45 / +23	14	2	6 - 10 - 15 - 16
8	+27 / +5	12	+55 / +28	16	2	8 - 10 - 12 - 15 - 16
9	+27 / +5	14	+55 / +28	19	2,5	6 - 10 - 14
10	+27 / +5	13	+55 / +28	16	1,5	10 - 16 - 20
10	+27 / +5	14	+55 / +28	18	2	10 - 15 - 20
10	+27 / +5	15	+55 / +28	20	3	10 - 15 - 16 - 20
10	+27 / +5	16	+55 / +28	22	3	8 - 10 - 16
12	+33 / +6	15	+55 / +28	18	1,5	12 - 16 - 20
12	+33 / +6	17	+55 / +28	22	3	10 - 12 - 15 - 16 - 20 - 25
12	+33 / +6	18	+55 / +28	24	3	8 - 12 - 20
14	+33 / +6	18	+55 / +28	22	2	14 - 18 - 22
14	+33 / +6	20	+68 / +35	25	3	14 - 15 - 18 - 20 - 22 - 25 - 28 - 30
15	+33 / +6	19	+68 / +35	23	2	16 - 20 - 25
15	+33 / +6	20	+68 / +35	25	3	15 - 20 - 25 - 30
15	+33 / +6	21	+68 / +35	27	3	10 - 15 - 16 - 20 - 25 - 32
16	+33 / +6	20	+68 / +35	24	2	16 - 20 - 25
16	+33 / +6	22	+68 / +35	28	3	15 - 16 - 20 - 25 - 30 - 32
18	+33 / +6	22	+68 / +35	26	2	18 - 22 - 28
18	+33 / +6	24	+68 / +35	30	3	18 - 22 - 28
18	+33 / +6	25	+68 / +35	32	4	20 - 25 - 30 - 35
20	+40 / +7	24	+68 / +35	28	2	10 - 16 - 20 - 25
20	+40 / +7	26	+68 / +35	32	3	15 - 16 - 20 - 25 - 30 - 32
20	+40 / +7	28	+68 / +35	35	4	20 - 25 - 30 - 35
22	+40 / +7	27	+68 / +35	32	2,5	18 - 22 - 28
22	+40 / +7	28	+68 / +35	33	4	15 - 20 - 25 - 30 - 35 - 40
22	+40 / +7	29	+68 / +35	36	3,5	18 - 22 - 28 - 36
25	+40 / +7	30	+68 / +35	35	2,5	20 - 25 - 32
25	+40 / +7	32	+82 / +43	40	4	20 - 25 - 30 - 32 - 35 - 40

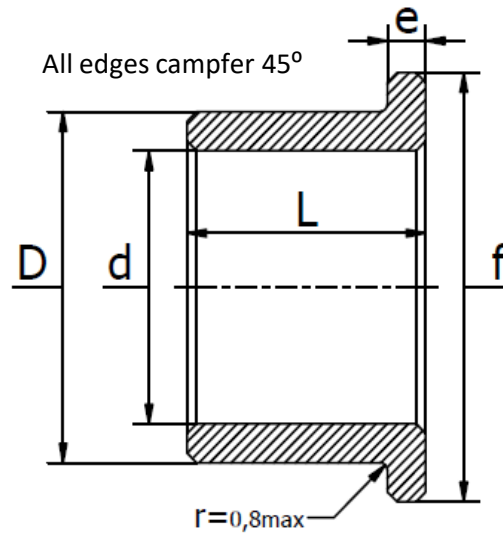

Diameter before fitting

d (mm)	tolerance G7 (μm)	D (mm)	tolerance s7 (μm)	f (mm)	e (mm)	L = Available lengths, tolerance js13
25	+40 / +7	35	+82 / +43	45	5	16 - 25 - 30
28	+40 / +7	33	+82 / +43	38	2,5	22 - 28 - 36
28	+40 / +7	36	+82 / +43	44	4	22 - 25 - 28 - 30 - 35 - 36 - 40
30	+40 / +7	38	+82 / +43	46	4	20 - 25 - 30
30	+40 / +7	40	+82 / +43	48	4	25 - 30 - 35 - 40
32	+48 / +9	38	+82 / +43	44	3	20 - 25 - 32
32	+48 / +9	40	+82 / +43	48	4	20 - 25 - 30 - 32 - 35 - 40
35	+48 / +9	45	+82 / +43	55	5	20 - 25 - 30 - 35 - 40
36	+48 / +9	42	+82 / +43	48	3	22 - 28 - 36
36	+48 / +9	45	+82 / +43	54	4,5	22 - 28 - 36
40	+48 / +9	46	+82 / +43	52	3	25 - 32 - 40
40	+48 / +9	50	+82 / +43	60	5	25 - 30 - 32 - 35 - 40
45	+48 / +9	51	+99 / +53	57	3	28 - 36 - 45
45	+48 / +9	56	+99 / +53	67	5,5	28 - 36 - 45
50	+48 / +9	56	+99 / +53	62	3	32 - 40 - 50
50	+48 / +9	60	+99 / +53	70	5	32 - 40 - 50
60	+56 / +10	70	+105 / +59	80	5	50 - 60