

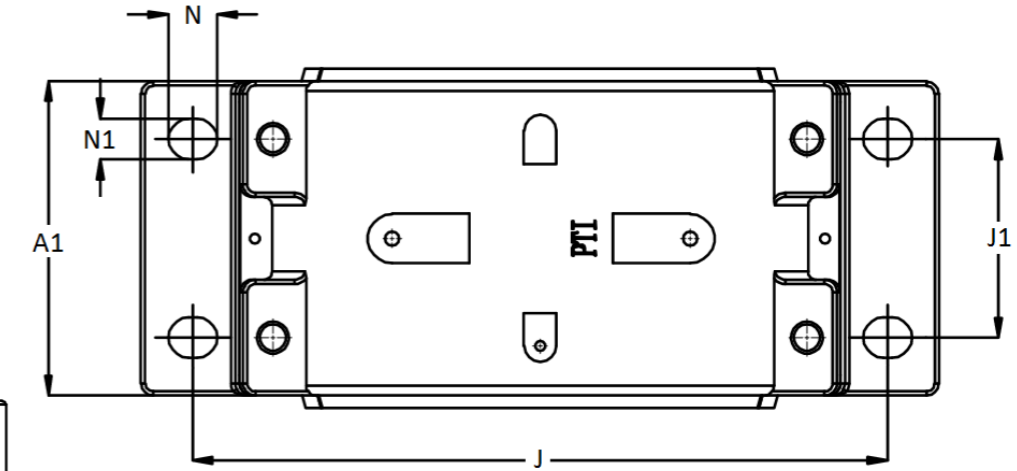

SD 3200 G Series - Split Plummer Block Housings (SNL 3200 G)

for spherical roller bearings on a cylindrical shaft, labyrinth seal, cast iron GG 20, incl. eye bolt.

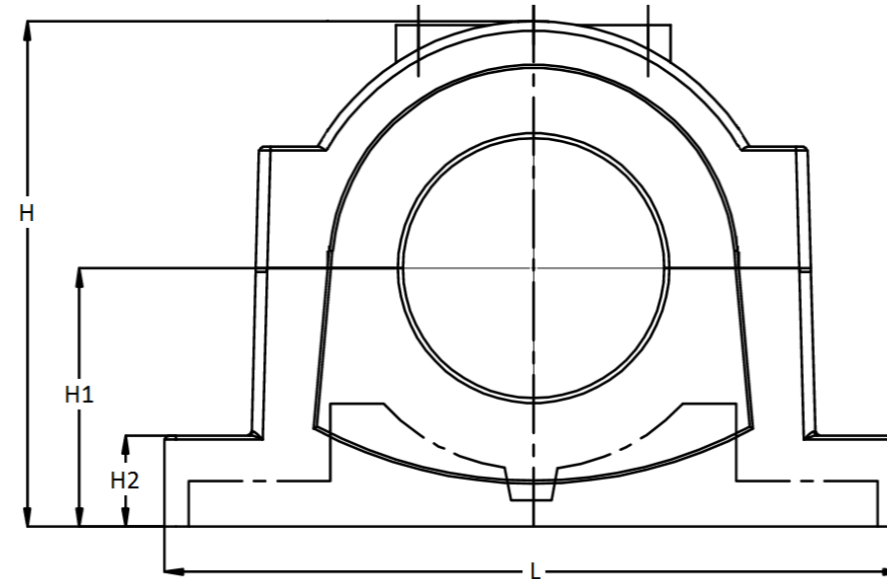
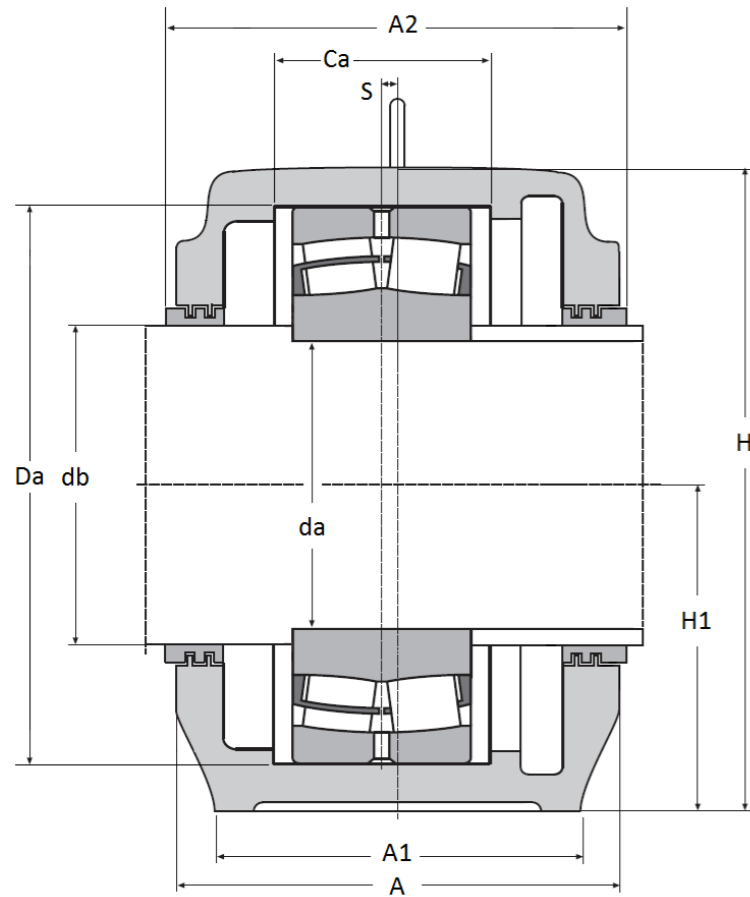

Housing No.	Shaft		Dimensions (mm)										Mounting		Weight (kg)	Labyrinth Seals	Bearing	Fixing Rings	End cover	O-Ring \varnothing * Length	Grease Qty First filling			
	da	db	Da	Ca	A	A1	A2	H	H1	H2	L	J	J1	N								N1	S	Bolt
SD 3234 G	170	190	310	122	260	210	270	375	190	80	560	480	120	34	28	10	M24	98	TS 40-190	23234	2 x FR 310-6	ETS36	4 x 660	1,9 kg
SD 3236 G	180	200	320	124	260	210	270	375	190	80	560	480	120	34	28	10	M24	98	TS 44	23236	2 x FR 320-6	ETS44	4 x 690	1,9 kg
SD 3238 G	190	210	340	132	280	230	290	411	210	85	610	510	130	42	35	10	M30	123	TS 48-210	23238	2 x FR 340-6	ETS48	4 x 730	2,2 kg
SD 3240 G	200	220	360	140	290	240	300	434	220	90	640	540	140	42	35	12	M30	139	TS 48-220-295	23240	2 x FR 360-6	ETS56	4 x 760	2,5 kg
SD 3244 G	220	240	400	148 (164)*	310	260	315	474	240	95	700	600	150	42	35	12	M30	187	TS 56-240	23244	2 x FR 400-10**	ETS52	4 x 830	3,0 kg
SD 3248 G	240	260	440	164 (180)*	320	280	330	516	260	100	770	650	160	50	42	13	M36	221	TS 60-260	23248	2 x FR 440-10**	ETS60	4 x 900	3,8 kg
SD 3252 G	260	280	480	181 (194)*	350	310	360	591	300	110	830	710	190	50	42	22	M36	301	TS 64-280	23252	2 x FR 480-10**	ETS64	4 x 970	5,6 kg
SD 3256 G	280	300	500	180 (196)*	350	310	360	591	300	110	830	710	190	50	42	22	M36	301	TS 68-300	23256	2 x FR 500-10**	ETS64	4 x 1000	5,6 kg
SD 3260 G	300	320	540	196 (212)*	370	330	380	631	320	115	880	750	200	50	42	23	M36	339	TS 72-320	23260	2 x FR 540-10**	ETS68	4 x 1100	6,9 kg
SD 3264 G	320	340	580	210 (228)*	400	360	410	675	340	120	950	810	220	50	42	24	M36	415	TS 76-340	23264	2 x FR 580-10**	ETS76	4 x 1180	8,6 kg
SD 3268 G	340	370	620	214 (234)*	400	360	410	715	360	120	1040	870	220	50	42	30	M36	470	TS 76-370	23265	2 x FR 620-5**	ETS80	4 x 1280	8,4 kg

* C_a dimension narrower than standard, can be used without fixing rings or special narrower rings. For wider dimensions marked in parenthesis, please request an offer.

** only for wide C_a versions as mentioned above.

These Housings can also be manufactured of ductile iron or cast steel. Special kevlar or felt seals on request.