

SN 200 Series - Plummer block housings (split)

For spherical ball and roller bearings on a cylindrical shaft, felt seals included, cast iron GG 20. Also available in ductile iron (GGG), with lubricating and grease outlet holes and grease quantity regulator.

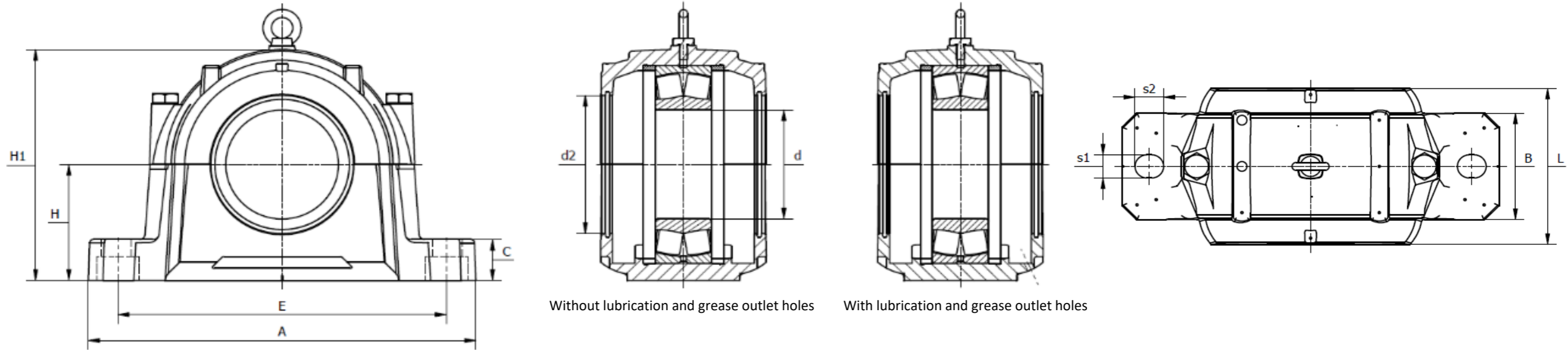

Part No.	Shaft size d (mm)	Dimensions (mm)										Mounting Bolt	Bearing	Fixing Rings	Housing No.	End cover	Weight (kg)
		d2	A	E	L	B	H1	H	C	s1	s2						
SN 205	25	30	165	130	67	46	75	40	19	15	20	M12	1205	2 x FR 52-5	SN 205	ASNH505	1,10
													2205	1 x FR 52-7			
													22205	1 x FR 52-7			
SN 206	30	35	185	150	77	52	90	50	22	15	20	M12	1206	2 x FR 62-7	SN206	ASNH506-605	1,60
													2206	1 x FR 62-10			
													22206	1 x FR 62-10			
SN 207	35	45	185	150	82	52	95	50	22	15	20	M12	1207	2 x FR 72-8	SN 207	ASNH507-606	1,90
													2207	1 x FR 72-10			
													22207	1 x FR 72-10			
SN 208	40	50	205	170	85	60	110	60	25	15	20	M12	1208	2 x FR 80-7,5	SN 208	ASNH509	2,60
													2208	1 x FR 80-10			
													22208	1 x FR 80-10			
SN 209	45	55	205	170	85	60	110	60	25	15	20	M12	1209	2 x FR 85-6	SN 209	ASNH510-608	2,80
													2209	1 x FR 85-8			
													22209	1 x FR 85-8			
SN 210	50	60	205	170	90	60	115	60	25	15	20	M12	1210	2 x FR 90-6,5	SN 210	ASNH511-609	3,00
													2210	1 x FR 90-10			
													22210	1 x FR 90-10			

SN 200 Series - Plummer block housings (split)

For spherical ball and roller bearings on a cylindrical shaft, felt seals included, cast iron GG 20. Also available in ductile iron (GGG), with lubricating and grease outlet holes and grease quantity regulator.

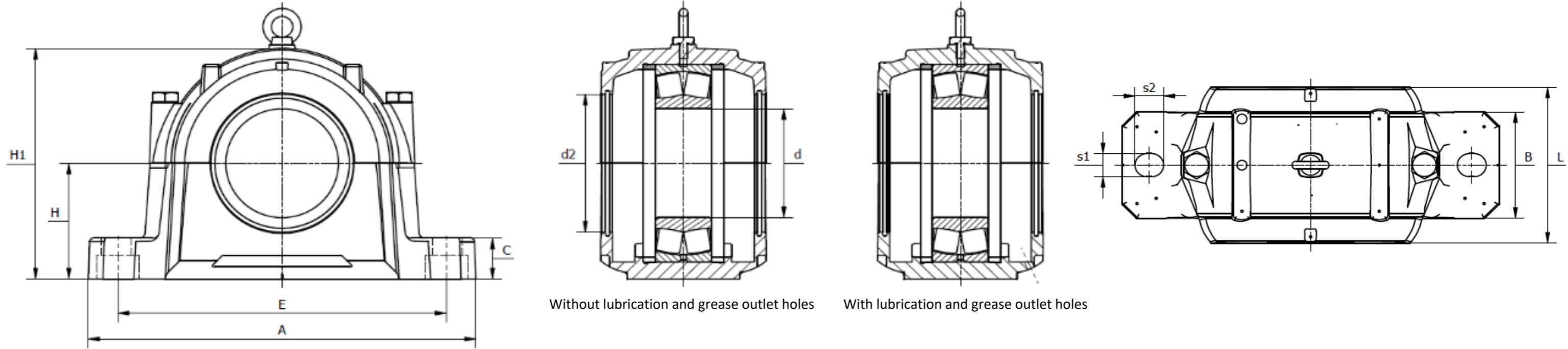

Part No.	Shaft size d (mm)	Dimensions (mm)										Mounting Bolt	Bearings	Fixing Rings	Housing No.	End cover	Weight (kg)
		d2	A	E	L	B	H1	H	C	s1	s2						
SN 211	55	65	255	210	95	70	130	70	28	18	23	M16	1211	2 x FR 100-6	SN 211	ASNH512-610	4,00
													2211	1 x FR 100-8			
													22211	1 x FR 100-8			
SN 212	60	70	255	210	105	70	135	70	28	18	23	M16	1212	2 x FR 110-8	SN 212	ASNH513-611	4,60
													2212	1 x FR 110-10			
													22212	1 x FR 110-10			
SN 213	65	75	275	230	110	80	150	80	30	18	23	M16	1213	2 x FR 120-10	SN 213	Optional	5,90
													2213	1 x FR 120-10			
													22213	1 x FR 120-12			
SN 214	70	80	275	230	115	80	157	80	30	18	23	M16	1214	2 x FR 125-10	SN 214	ASNH515-612	6,50
													2214	1 x FR 125-13			
													22214	1 x FR 125-13			
SN 215	75	85	280	230	115	80	155	80	30	18	23	M16	1215	2 x FR 130-8	SN 215	ASNH516-613	6,70
													2215	1 x FR 130-10			
													22215	1 x FR 130-10			
SN 216	80	90	315	260	120	90	175	95	32	22	27	M20	1216	2 x FR 140-8,5	SN 216	ASNH517	8,50
													2216	1 x FR 140-10			
													22216	1 x FR 140-10			

SN 200 Series - Plummer block housings (split)

For spherical ball and roller bearings on a cylindrical shaft, felt seals included, cast iron GG 20. Also available in ductile iron (GGG), with lubricating and grease outlet holes and grease quantity regulator.

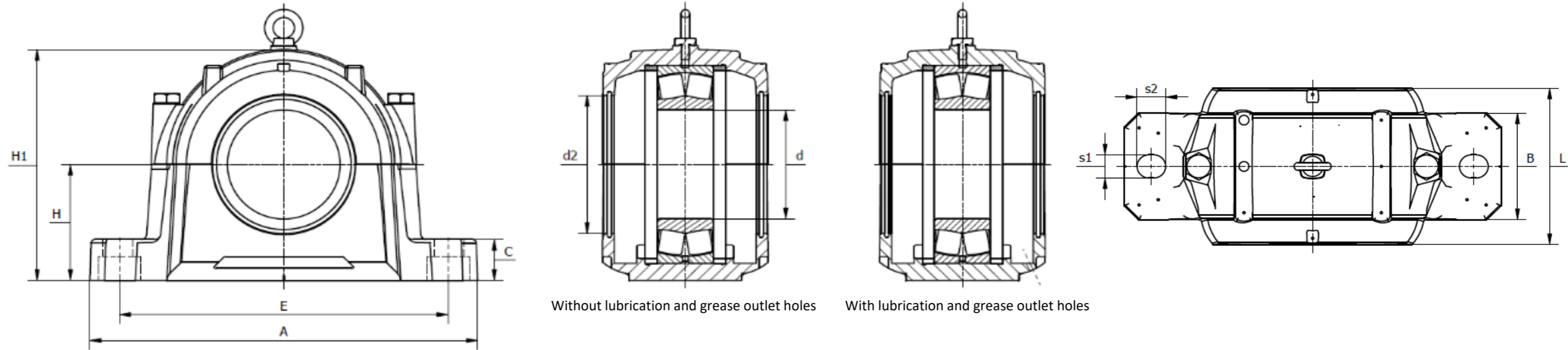

Part No.	Shaft size d (mm)	Dimensions (mm)										Mounting Bolt	Bearings	Fixing Rings	Housing No.	End cover	Weight (kg)
		d2	A	E	L	B	H1	H	C	s1	s2						
SN 217	85	95	320	260	125	90	185	95	32	22	27	M20	1217	2 x FR 150-9	SN 217	ASNH518-615	9,30
													2217	1 x FR 150-10			
													22217	1 x FR 150-10			
SN 218	90	100	345	290	145	100	195	100	35	22	27	M20	1218	2 x FR 160-16,2	SN 218	Optional	11,80
													2218	2 x FR 160-11,2			
													22218	2 x FR 160-11,2			
													23218	1 x FR 160-10			
SN 219	95	110	345	290	140	100	210	112	35	22	27	M20	1219	1 x FR 170-10,5	SN 219	Optional	13,00
													2219	1 x FR 170-10			
													22219	1 x FR 170-10			
SN 220	100	115	380	320	160	110	215	112	40	26	32	M24	1220	2 x FR 180-18,1	SN 220	Optional	13,60
													2220	2 x FR 180-12,1			
													22220	2 x FR 180-12,1			
													23220	1 x FR 180-10			
SN 222	110	125	410	350	175	120	240	125	45	26	32	M24	1222	2 x FR 200-21	SN 222	ASNH519-616	15,50
													2222	2 x FR 200-13,5			
													22222	2 x FR 200-13,5			
													23222	1 x FR 200-10			

SN 200 Series - Plummer block housings (split)

For spherical ball and roller bearings on a cylindrical shaft, felt seals included, cast iron GG 20. Also available in ductile iron (GGG), with lubricating and grease outlet holes and grease quantity regulator.

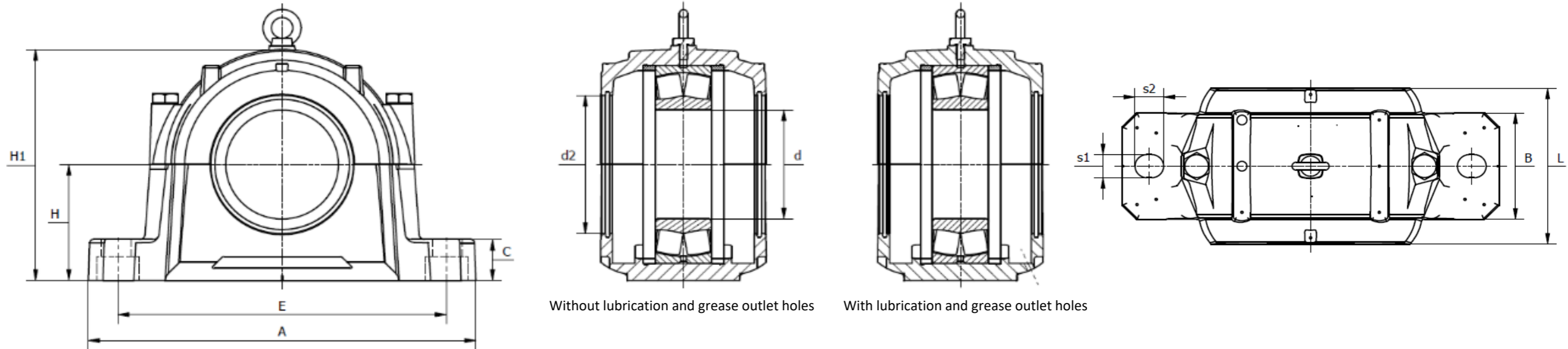

Part No.	Shaft size d (mm)	Dimensions (mm)										Mounting Bolt	Bearings	Fixing Rings	Housing No.	End cover	Weight (kg)
		d2	A	E	L	B	H1	H	C	s1	s2						
SN 224	120	135	410	350	185	120	270	140	45	26	32	M24	22224	2 x FR 215-14	SN 224	ASNH522-619	19,80
													23224	2 x FR 215-10			
SN 226	130	145	445	380	190	130	290	150	50	26	35	M24	22226	2 x FR 230-13	SN 226	Optional	22,40
													23226	1 x FR 230-10			
SN 228	140	155	500	420	205	150	305	150	50	35	42	M30	22228	2 x FR 250-15	SN 228	Optional	28,30
													23228	1 x FR 259-10			
SN 230	150	165	530	450	220	160	325	160	60	35	42	M30	22230	2 x FR 270-16,5	SN 230	Optional	36,00
													23230	1 x FR 270-10			
SN 232	160	175	550	470	235	160	345	170	60	35	42	M30	22232	2 x FR 290-17	SN 232	ASNH530	43,10
													23232	1 x FR 290-10			