

Felt seal, Rubber seal and V-ring seal

Labyrinth seal

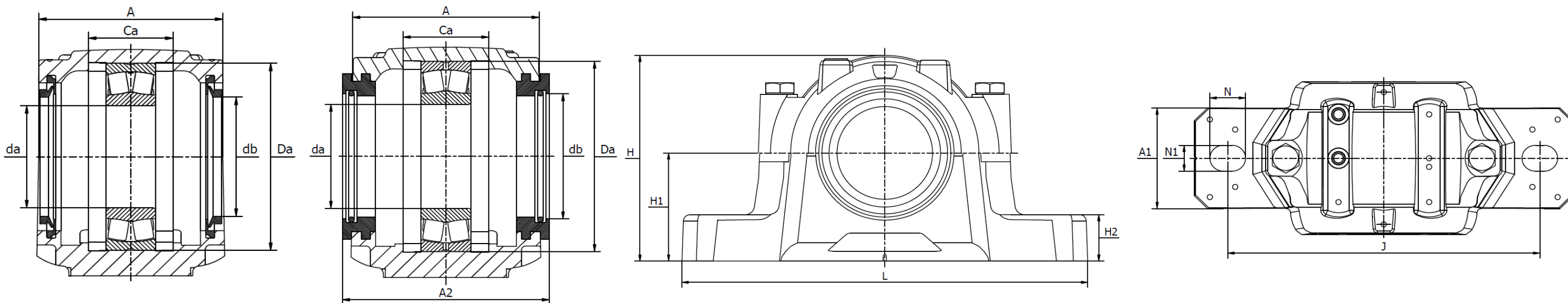

Part No.	Shaft size (mm)		Dimensions (mm)												Mounting bolt	Bearings	Fixing rings	Housing No.	Double Lip seals	V-ring seals	Felt seals	Labyrinth seals	End cover	Weight (kg)
	da	db	A	A1	A2	Ca	Da	H	H1	H2	J	L	N	N1										
SNHF 305	25	30	77	52	89	32	62	89	50	22	150	185	20	15	M12	1305	2 x FR 62-7.5	SNHF 206	TSN305G	TSN305A	TSN305C	TS05-305	ASNH507-606	1,9
																2305	2 x FR 62-4							
																21305	2 x FR 62-7.5							
SNHF 306	30	35	82	52	94	34	72	93	50	22	150	185	20	15	M12	1306	2 x FR 72-7.5	SNHF 507-606	TSN306G	TSN306A	TSN306C	TS 06-306	ASNH507-606	2,2
																2306	2 x FR 72-3.5							
																22206	2 x FR 72-7.5							
SNHF 307	35	45	85	60	99	39	80	108	60	25	170	205	20	15	M12	1307	2 x FR 80-9	SNHF 208-307	TSN307G	TSN307A	TSN307C	TS07-307	ASNH510-608	2,9
																2307	2 x FR 80-4							
																21307	2 x FR 80-9							
SNHF 308	40	50	90	60	102	41	90	113	60	25	170	205	20	15	M12	1308	2 x FR 90-9	SNHF 510-608	TSN308G	TSN308A	TSN308C	TS08-308	ASNH510-608	3,2
																2308	2 x FR 90-4							
																21308	2 x FR 90-9							
																22308	2 x FR 90-4							
SNHF 309	45	55	95	70	107	44	100	128	70	28	210	255	24	18	M16	1309	2 x FR 100-9.5	SNHF 511-609	TSN309G	TSN309A	TSN309C	TS09-309	ASNH511-609	4,4
																2309	2 x FR 100-4							
																21309	2 x FR 100-9.5							
																22309	2 x FR 100-4							
SNHF 310	50	60	105	70	117	48	110	134	70	30	210	255	24	18	M16	1310	2 x FR 110-10.5	SNHF 512-610	TSN310G	TSN310A	TSN310C	TS10-310	ASNH512-610	5,1
																2310	2 x FR 110-4							
																21310	2 x FR 110-10.5							
																22310	2 x FR 110-4							

Felt seal, Rubber seal and V-ring seal

Labyrinth seal

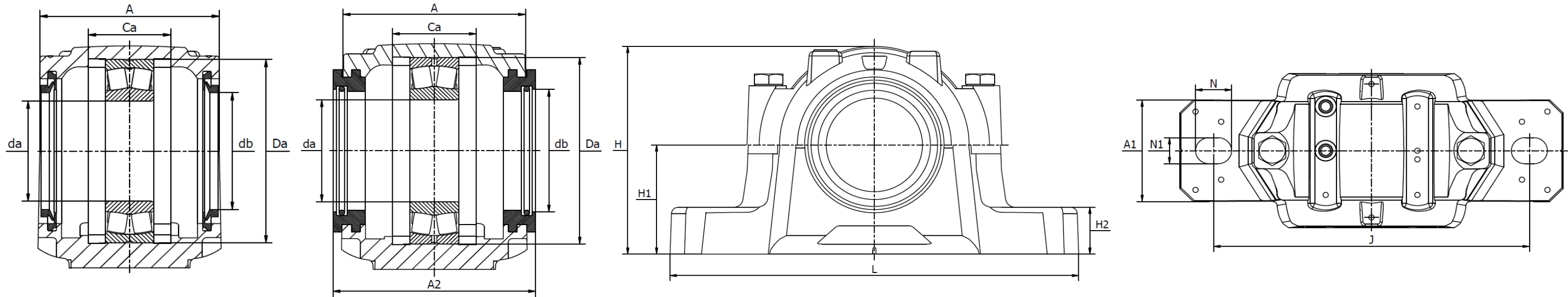

Part No.	Shaft size (mm)		Dimensions (mm)												Mounting bolt	Bearings	Fixing rings	Housing No.	Double Lip seals	V-ring seals	Felt seals	Labyrinth seals	End cover	Weight (kg)
	da	db	A	A1	A2	Ca	Da	H	H1	H2	J	L	N	N1										
SNHF 311	55	65	110	80	122	51	120	149	80	30	230	275	24	18	M16	1311	2 x FR 120-11	SNHF 513-611	TSN311G	TSN311A	TSN311C	TS11-311	ASNH513-611	6,5
																2311	2 x FR 120-4							
																21311	2 x FR 120-11							
																22311	2 x FR 120-4							
SNHF 312	60	70	115	80	127	56	130	155	80	30	230	280	24	18	M16	1312	2 x FR 130-12.5	SNHF 515-612	TSN312G	TSN312A	TSN312C	TS12-312	ASNH515-612	7,0
																2312	2 x FR 130-5							
																21312	2 x FR 130-12.5							
																22312	2 x FR 130-5							
SNHF 313	65	75	120	90	138	58	140	177	95	32	260	315	28	22	M20	1313	2 x FR 140-12.5	SNHF 516-613	TSN313G	TSN313A	TSN313C	TS13-313	ASNH516-613	9,5
																2313	2 x FR 140-5							
																21313	2 x FR 140-12.5							
																22313	2 x FR 140-5							
SNHF 314	70	80	125	90	143	61	150	183	95	32	260	320	28	22	M20	1314	2 x FR 150-13	SNHF 517	TSN314G	TSN314A	TSN314C	TS14-314	ASNH517	10,0
																2314	2 x FR 150-5							
																21314	2 x FR 150-13							
																22314	2 x FR 150-5							
SNHF 315	75	85	140	100	158	65	160	194	100	35	290	345	28	22	M20	1315	2 x FR 14/160	SNHF 518-615	TSN315G	TSN315A	TSN315C	TS15-315	ASNH518-615	12,5
																2315	2 x FR 160-5							
																21315	2 x FR 160-14							
																22315	2 x FR 160-5							

Felt seal, Rubber seal and V-ring seal

Labyrinth seal

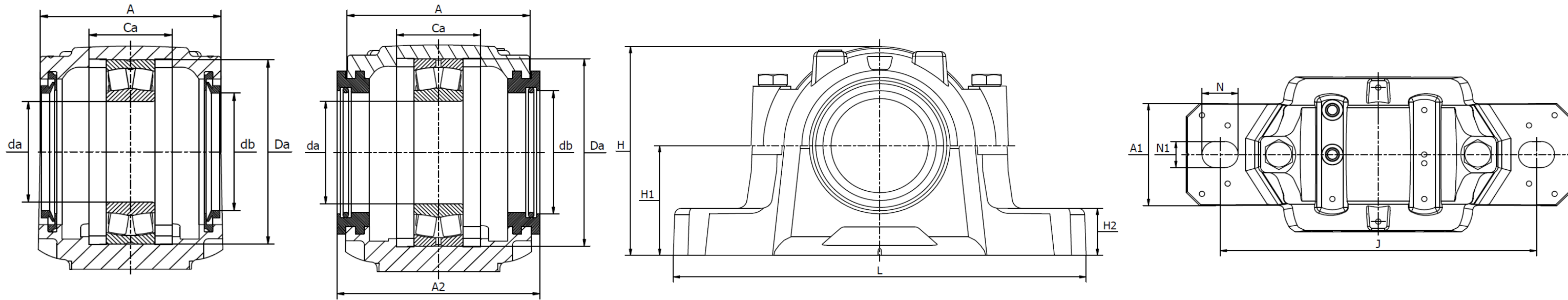

Part No.	Shaft size (mm)		Dimensions (mm)												Mounting bolt	Bearings	Fixing rings	Housing No.	Double Lip seals	V-ring seals	Felt seals	Labyrinth seals	End cover	Weight (kg)
	da	db	A	A1	A2	Ca	Da	H	H1	H2	J	L	N	N1										
SNHF 316	80	90	145	100	163	68	170	212	112	35	290	345	28	22	M20	1316	2 x FR 170-14.5	SNHF 519-616	TSN316G	TSN316A	TSN316 C	TS16-316	ASNH519-616	13,7
																2316	2 x FR 170-5							
																21316	2 x FR 170-14.5							
																22316	2 x FR 170-5							
SNHF 317	85	95	160	110	178	70	180	218	112	40	320	380	32	26	M24	1317	2 x FR 180-14.5	SNHF 520-617	TSN317G	TSN317A	TSN317C	TS17-317	ASNH520-617	17,6
																2317	2 x FR 180-5							
																21317	2 x FR 180-14.5							
																22317	2 x FR 180-5							
SNHF 319	95	110	175	120	191	80	200	242	125	45	350	410	32	26	M24	1319	2 x FR 200-17.5	SNHF 522-619	TSN319G	TSN319A	TSN319C	TS19-319	ASNH522-619	22,0
																2319	2 x FR 200-6.5							
																21319	2 x FR 200-17.5							
																22319	2 x FR 200-6.5							
SNHF 320	100	115	185	120	199	86	215	271	140	45	350	410	32	26	M24	1320	2 x FR 215-19.5	SNHF 524-620	TSN320G	TSN320A	TSN320C	TS20-320	ASNH524-620	26,2
																2320	2 x FR 215-6.5							
																21320	2 x FR 215-19.5							
																22320	2 x FR 215-6.5							