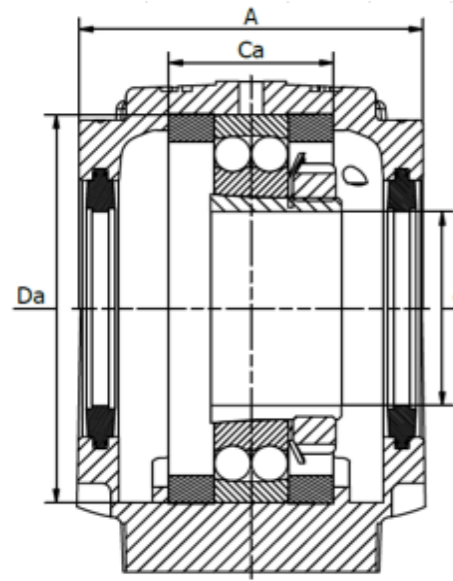
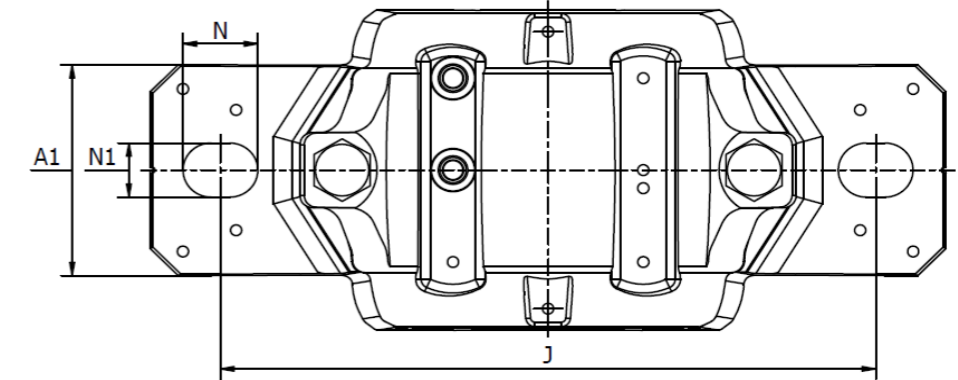
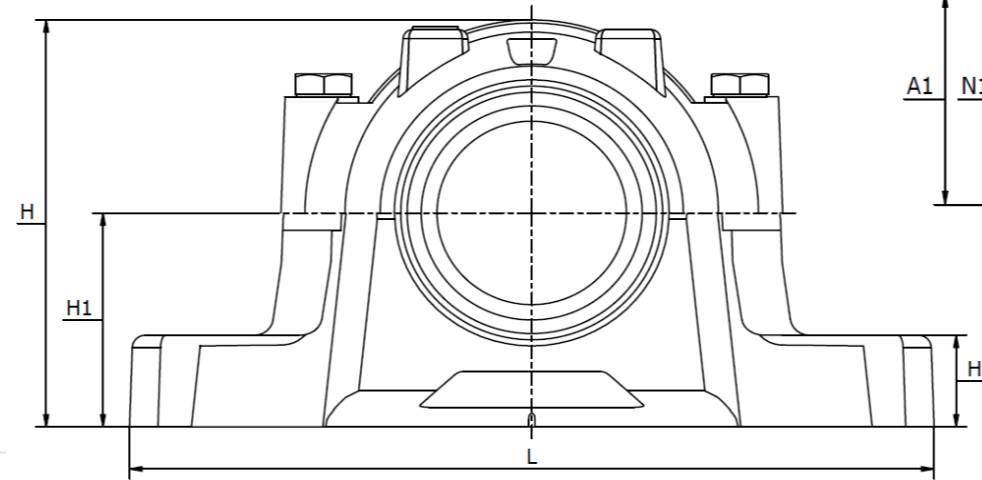
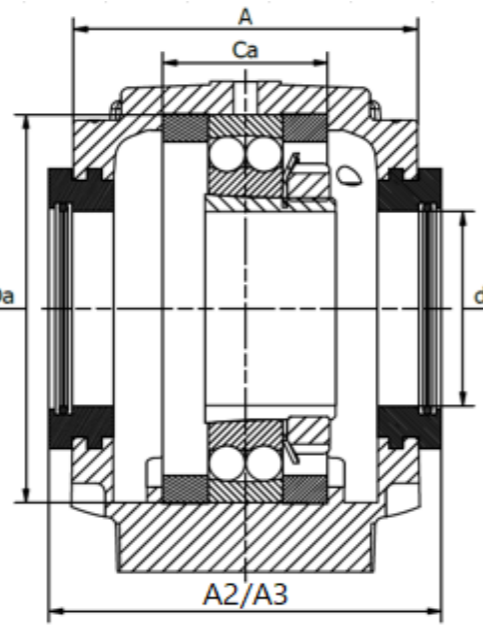

Felt seal, Rubber seal and V-ring seal

Labyrinth A2 / Taconite A3

Part No.	Shaft size	Dimensions (mm)												Mounting bolt	Bearings	Adapter sleeves	Fixing rings	Housing No.	Double Lip seals	V-ring seals	Felt seals	Labyrinth seals	Taconite seals	End cover	Weight (kg)	
		A	A1	A2	A3	Ca	Da	H	H1	H2	J	L	N													N1
SNHF 505	20	67	46	80	120	25	52	74	40	19	130	165	20	15	M12	1205 K	H 205	2 x FR 52-5	SNHF 505	TSN505G	TSN505A	TSN505C	TS05	TSN505ND	ASNH505	1,45
																2205 K	H 305	2 x FR 52-3.5								
																22205 K	H 305	2 x FR 52-3.5								
SNHF 506	25	77	52	89	130	32	62	89	50	22	150	185	20	15	M12	1206 K	H 206	2 x FR 62-8	SNHF 506-605	TSN506G	TSN506A	TSN506C	TS06	TSN506ND	ASNH506-605	2
																2206 K	H 306	2 x FR 62-6								
																22206 K	H 306	2 x FR 62-6								
SNHF 507	30	82	52	94	135	34	72	93	50	22	150	185	20	15	M12	1207 K	H 207	2 x FR 72-8.5	SNHF 507-606	TSN507G	TSN507A	TSN507C	TS07	TSN506ND	ASNH507-606	2,2
																2207 K	H 307	2 x FR 72-5.5								
																22207 K	H 307	2 x FR 72-5.5								
SNHF 508	35	85	60	97	140	39	80	107	60	25	170	205	20	15	M12	1208 K	H 208	2 x FR 80-10.5	SNHF 508-607	TSN508G	TSN508A	TSN508C	TS08	TSN508ND	ASNH508-607	2,9
																2208 K	H 308	2 x FR 80-8								
																22208 K	H 308	2 x FR 80-8								
SNHF 509	40	85	60	97	145	30	85	109	60	25	170	205	20	15	M12	1209 K	H 209	2 x FR 85-5.5	SNHF 509	TSN509G	TSN509A	TSN509C	TS09	TSN509ND	ASNH509	2,9
																2209 K	H 309	2 x FR 85-3.5								
																22209 K	H 309	2 x FR 85-3.5								
SNHF 510	45	90	60	102	150	41	90	113	60	25	170	205	20	15	M12	1210 K	H 210	2 x FR 90-10.5	SNHF 510-608	TSN510G	TSN510A	TSN510C	TS10	TSN510ND	ASNH510-608	3,2
																2210 K	H 310	2 x FR 90-9								
																22210 K	H 310	2 x FR 90-9								

SNHF 500 Series - Plummer block housings (SNH/SNL/SNV)

For spherical ball and roller bearings on adapter sleeves, options for different sealing types, cast iron GG 20, Rp 1/8" (SNHF 505+506 = M8) grease bore thread.

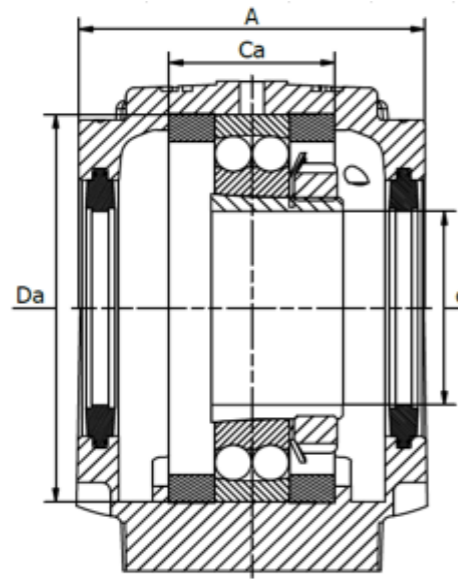
Felt seal, Rubber seal and V-ring seal



Labyrinth A2 / Taconite A3

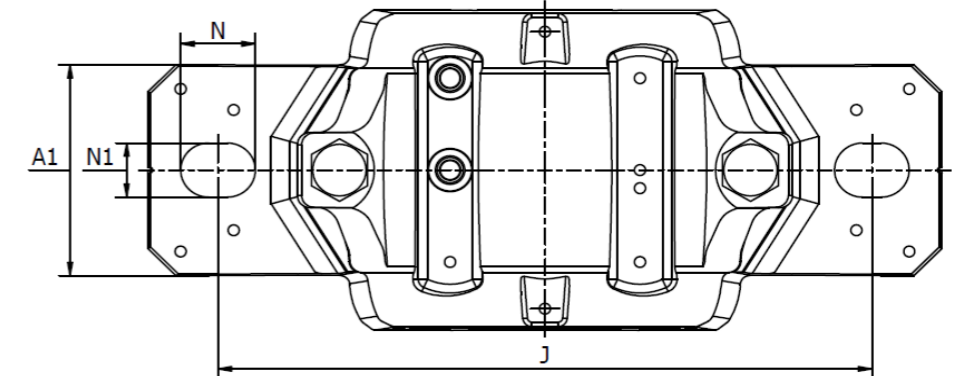
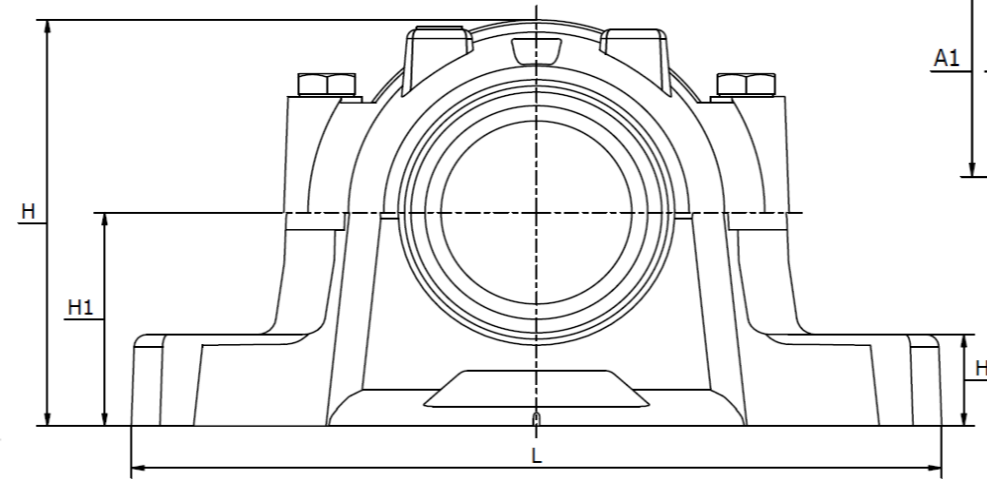
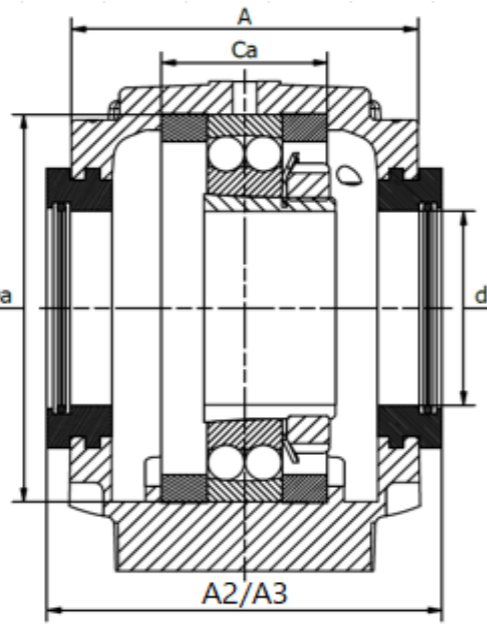

Part No.	Shaft size	Dimensions (mm)											Mounting bolt	Bearings	Adapter sleeves	Fixing rings	Housing No.	Double Lip seals	V-ring seals	Felt seals	Labyrinth seals	Taconite seals	End cover	Weight (kg)		
		A	A1	A2	A3	Ca	Da	H	H1	H2	J	L													N	N1
SNHF 511	50	95	70	107	155	44	100	127	70	28	210	255	24	18	M16	1211 K	H 211	2 x FR 100-11.5	SNHF 511-609	TSN511G	TSN511A	TSN511C	TS11	TSN511ND	ASNH511-609	4,4
																2211 K	H 311	2 x FR 100-9.5								
																22211 K	H 311	2 x FR 100-9.5								
SNHF 512	55	105	70	117	160	48	110	133	70	30	210	255	24	18	M16	1212 K	H 212	2 x FR 110-13	SNHF 512-610	TSN512G	TSN512A	TSN512C	TS12	TSN512ND	ASNH512-610	5,1
																2212 K	H 312	2 x FR 110-10								
																22212 K	H 312	2 x FR 110-10								
SNHF 513	60	110	80	122	170	51	120	148	80	30	230	275	24	18	M16	1213 K	H 213	2 x FR 120-14	SNHF 513-611	TSN513G	TSN513A	TSN513C	TS13	TSN513ND	ASNH 513-611	6,5
																2213 K	H 313	2 x FR 120-10								
																22213 K	H 313	2 x FR 120-10								
SNHF 515	65	115	80	127	175	56	130	154	80	30	230	280	24	18	M16	1215 K	H 215	2 x FR 130-15.5	SNHF 515-612	TSN515G	TSN515A	TSN515C	TS15	TSN515ND	ASNH515-612	7
																2215 K	H 315	2 x FR 130-12.5								
																22215 K	H 315	2 x FR 130-12.5								
SNHF 516	70	120	90	138	185	58	140	175	95	32	260	315	28	22	M20	1216 K	H 216	2 x FR 140-16	SNHF 516-613	TSN516G	TSN516A	TSN516C	TS16	TSN516ND	ASNH516-613	9,5
																2216 K	H 316	2 x FR 140-12.5								
																22216 K	H 316	2 x FR 140-12.5								
SNHF 517	75	125	90	143	190	61	150	183	95	32	260	320	28	22	M20	1217 K	H 217	2 x FR 150-16.5	SNHF 517	TSN517G	TSN517A	TSN517C	TS17	TSN517ND	ASNH517	10
																2217 K	H 317	2 x FR 150-12.5								
																22217 K	H 317	2 x FR 150-12.5								

SNHF 500 Series - Plummer block housings (SNH/SNL/SNV)

For spherical ball and roller bearings on adapter sleeves, options for different sealing types, cast iron GG 20, Rp 1/8" (SNHF 505+506 = M8) grease bore thread.

Felt seal, Rubber seal and V-ring seal

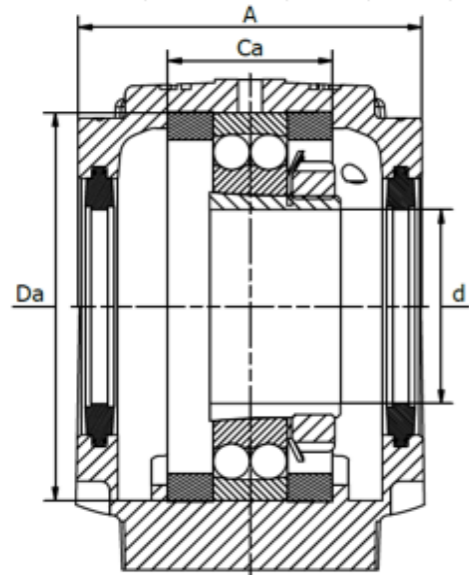

Labyrinth A2 / Taconite A3

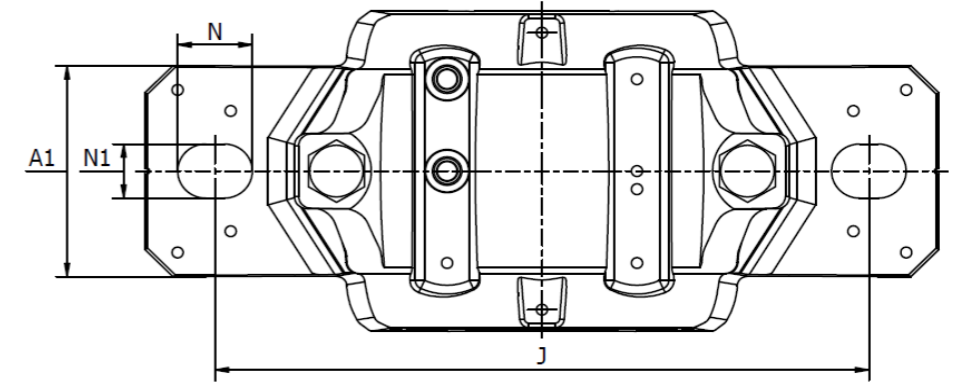
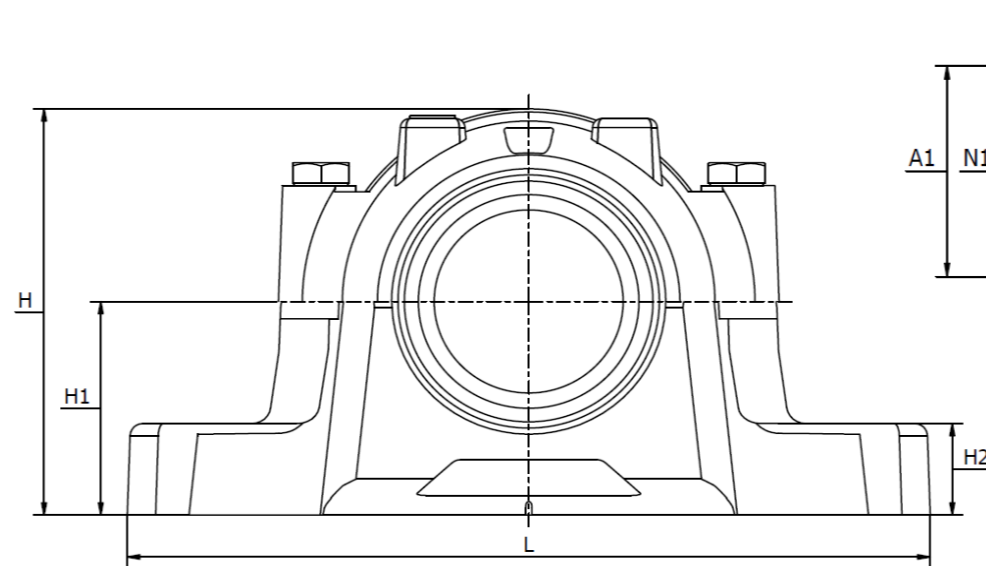
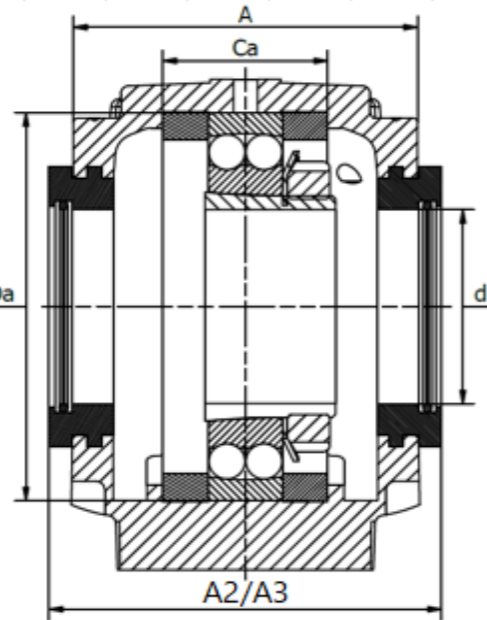

Part No.	Shaft size	Dimensions (mm)												Mounting bolt	Bearings	Adapter sleeves	Fixing sleeves	Housing No.	Double Lip seals	V-ring seals	Felt seals	Labyrinth seals	Taconite seals	End cover	Weight (kg)	
		A	A1	A2	A3	Ca	Da	H	H1	H2	J	L	N													N1
SNHF 518	80	140	100	158	210	65	160	193	100	35	290	345	28	22	M20	1218 K	H 218	2 x FR 160-17.5	SNHF 518-615	TSN518G	TSN518A	TSN518C	TS18	TSN518ND	ASNH518-615	12,5
																2218 K	H 318	2 x FR 160-12.5								
																22218 K	H 318	2 x FR 160-12.5								
																23218 K	H 2318	2 x FR 160-6.25								
SNHF 519	85	145	100	163	210	68	170	210	112	35	290	345	28	22	M20	1219 K	H 219	2 x FR 170-18	SNHF 519-616	TSN519G	TSN519A	TSN519C	TS19	TSN519ND	ASNH 519-616	13,7
																2219 K	H 319	2 x FR 170-12.5								
																22219 K	H 319	2 x FR 170-12.5								
SNHF 520	90	160	110	178	225	70	180	218	112	40	320	380	32	26	M24	1220 K	H 220	2 x FR 180-18	SNHF 520-617	TSN520G	TSN520A	TSN520C	TS20	TSN520ND	ASNH520-617	17,6
																2220 K	H 320	2 x FR 180-12								
																22220 K	H 320	2 x FR 180-12								
																23220 K	H 2320	2 x FR 180-4.85								
SNHF 522	100	175	120	191	240	80	200	239	125	45	350	410	32	26	M24	1222 K	H 222	2 x FR 200-21	SNHF 522-619	TSN522G	TSN522A	TSN522C	TS22	TSN522ND	ASNH522-619	22
																2222 K	H 322	2 x FR 200-13.5								
																22222 K	H 322	2 x FR 200-13.5								
																23222 K	H 2322	2 x FR 200-5.1								
SNHF 524	110	185	120	199	255	86	215	271	140	45	350	410	32	26	M24	1224 K	H 3124	2 x FR 215-22	SNHF 524-620	TSN524G	TSN524A	TSN524C	TS24	TSN524ND	ASNH524-620	26,2
																22224 K	H 3124	2 x FR 215-14								
																23224 K	H 2324	2 x FR 215-5								

SNHF 500 Series - Plummer block housings (SNH/SNL/SNV)

For spherical ball and roller bearings on adapter sleeves, options for different sealing types, cast iron GG 20, Rp 1/8" (SNHF 505+506 = M8) grease bore thread.

Felt seal, Rubber seal and V-ring seal

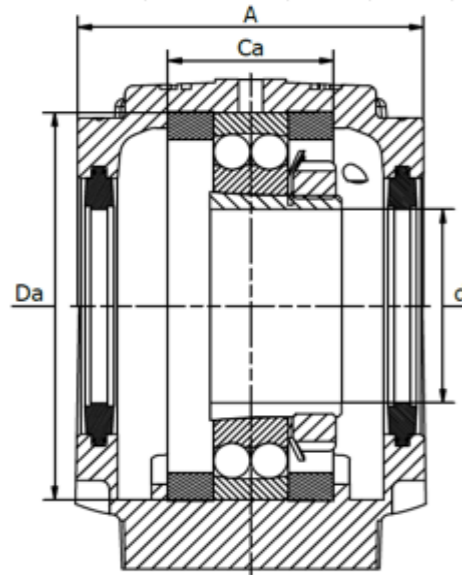

Labyrinth A2 / Taconite A3

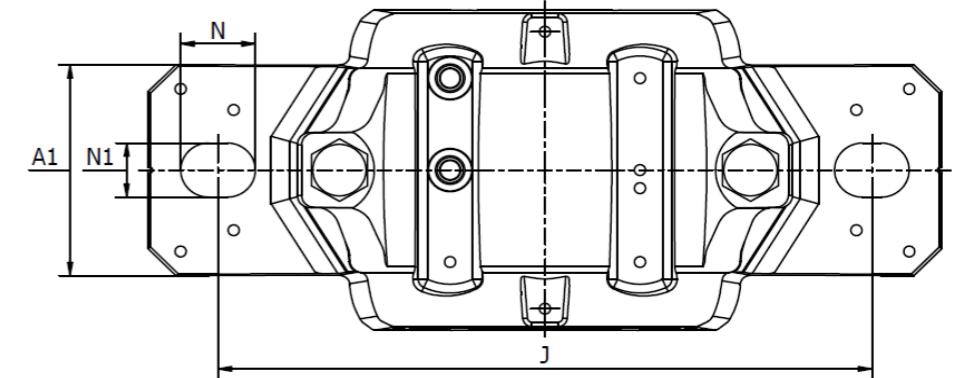
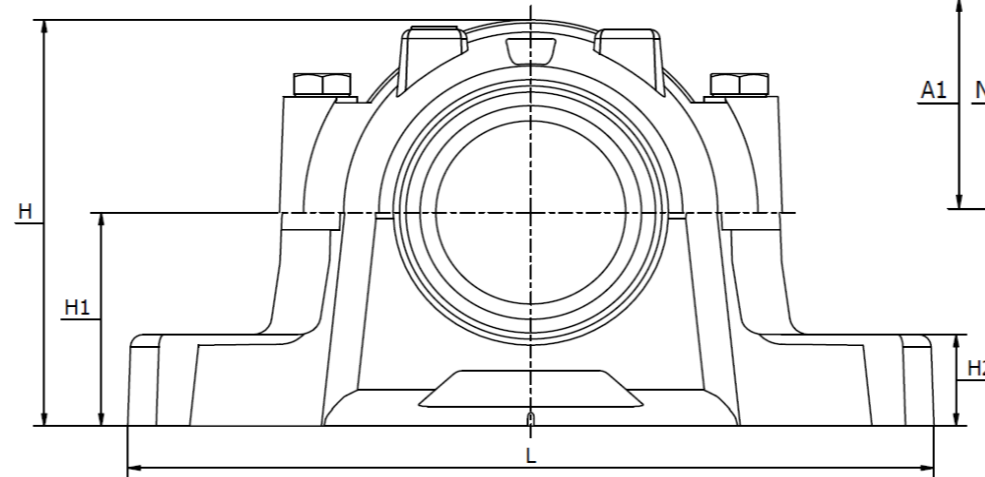
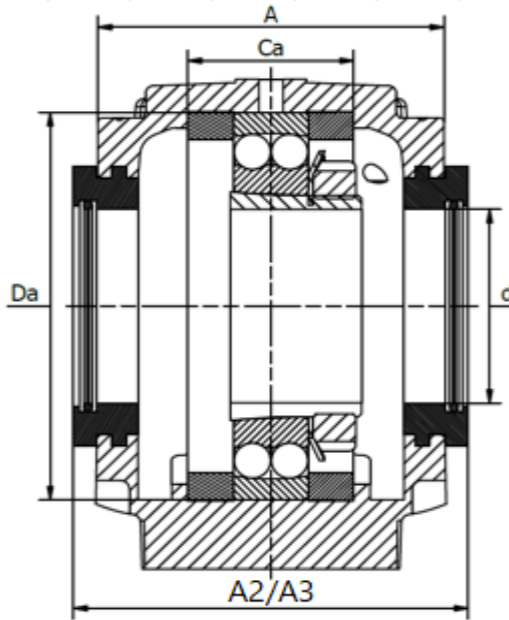

Part No.	Shaft size	Dimensions (mm)											Mounting bolt	Bearings	Adapter sleeve	Fixing rings	Housing No.	Double Lip seals	V-ring seals	Felt seals	Labyrinth seals	Taconite seals	End cover	Weight (kg)		
		A	A1	A2	A3	Ca	Da	H	H1	H2	J	L													N	N1
SNHF 526	115	190	130	208	260	90	230	290	150	50	380	445	35	28	M24	22226 K	H 3126	2 x FR 230-13	SNHF 526	TSN526G	TSN526A	TSN526C	TS26	TSN526ND	ASNH526	33
																23226 K	H 2326	2 x FR 230-5								
SNHF 528	125	205	150	223	275	98	250	302	150	50	420	500	42	35	M30	22228 K	H 3128	2 x FR 250-15	SNHF 528	TSN528G	TSN528A	TSN528C	TS28	TSN528ND	ASNH528	40
																23228 K	H 2328	2 x FR 250-5								
SNHF 530	135	220	160	241	290	106	270	323	160	60	450	530	42	35	M30	22230 K	H 3130	2 x FR 270-16.5	SNHF 530	TSN530G	TSN530A	TSN530C	TS30	TSN530ND	ASNH530	49
																23230 K	H 2330	2 x FR 270-5								
SNHF 532	140	235	160	254	305	114	290	344	170	60	470	550	42	35	M30	22232 K	H 3132	2 x FR 290-17	SNHF 532	TSN532G	TSN532A	TSN532C	TS32	TSN532ND	ASNH532	55
																23232 K	H 2332	2 x FR 290-5								