

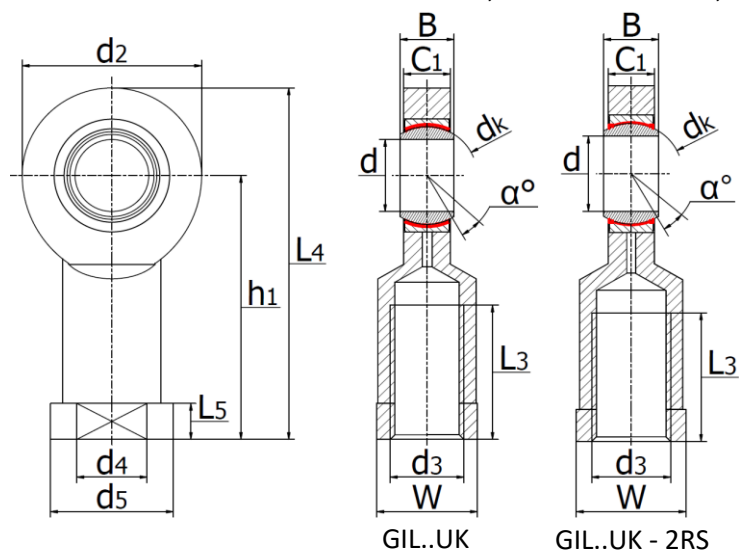

GIL..UK (2RS) - Rod ends

with internal thread, maintenance-free, to DIN ISO 12 240-4, left hand thread. (SIL .. C / SIL .. TE 2RS / EIL .. D)



Rod body with left-hand female thread.

It is made up of a radial spherical plain bearing GE..UK or GE..UK.2RS and rod body.

Surface of rod body zinc plated.

Material: Steel innerring, PTFE coated outerring.

Part No.		Dimensions (mm)													Load ratings (kN)		Weight	
Open	Sealed	d	d ₃	B	C ₁	L ₃	W	d ₂	h ₁	L ₄	L ₅	d ₄	d ₅	d _k	α	dyn. C	stat. C0	(kg)
GIL6UK	-	6	M6x1,0	6	4,4	11	11	21	30	40,5	5	10	13	10	13	3,6	8,15	0,021
GIL8UK	-	8	M8x1,25	8	6	15	14	24	36	48	5	12,5	16	13	15	5,85	12,9	0,039
GIL10UK	-	10	M10x1,5	9	7	20	17	29	43	57,5	6,5	15	19	16	12	8,65	17,6	0,061
GIL12UK	-	12	M12x1,75	10	8	23	19	34	50	67	6,5	17,5	22	18	11	11,4	24,5	0,096
GIL15UK	-	15	M14x2,0	12	10	30	22	40	61	81	8	21	26	22	8	17,6	36	0,18
GIL17UK	GIL17UK.2RS	17	M16x2,0	14	11	34	27	46	67	90	10	24	30	25	10	22,4	45	0,22
GIL20UK	GIL20UK.2RS	20	M20x1,5	16	13	40	32	53	77	103,5	10	27,5	35	29	9	31,5	60	0,35
GIL25UK	GIL25UK.2RS	25	M24x2,0	20	17	48	36	64	94	126	12	33,5	42	35,5	7	51	83	0,64
GIL30UK	GIL30UK.2RS	30	M30x2,0	22	19	56	41	73	110	146,5	15	40	50	40,7	6	66,5	110	0,93
-	GIL35UK.2RS	35	M36x3,0	25	21	60	50	82	125	166	15	47	58	47	6	112	146	1,3
-	GIL40UK.2RS	40	M39x3,0	28	23	65	55	92	142	188	18	52	65	53	7	140	180	2
-	GIL45UK.2RS	45	M42x3,0	32	27	65	60	102	145	196	20	58	70	60	7	180	240	2,5
-	GIL50UK.2RS	50	M45x3,0	35	30	68	65	112	160	216	20	62	75	66	6	220	290	3,5
-	GIL60UK.2RS	60	M52x3,0	44	38	70	75	135	175	242,5	20	70	88	80	6	345	450	5,5
-	GIL70UK.2RS	70	M56x4,0	49	42	80	85	160	200	280	20	80	98	92	6	440	610	8,6
-	GIL80UK.2RS	80	M64x4,0	55	47	85	100	180	230	320	25	95	110	105	6	570	750	12