

Our idler sprockets are supplied complete with bearings, ready to be fitted at the relevant tension or driving gear points. The accurate machining and stable assembly on a ball bearing, with double protection, provides greater resistance to loads and wear. The central "extended" ring on bearing, allows easy assembly on all types of special machinery.

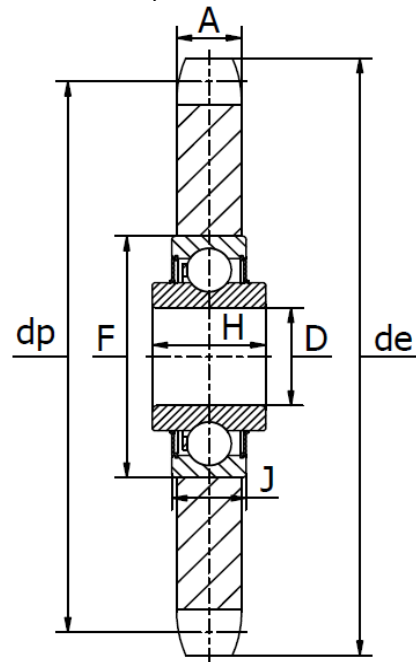

Product No.	Pitch	Dimensions							Bearing
		de	dp	A	D	F	H	J	
KKR 05 B-1 23T	8 x 3 mm	62,0	58,75	7	16 +0,13/+0,26	40	18,3	12	203 KRR
KKR 06 B-1 20T	3/8" x 7/32"	64,3	60,89	7	16 +0,13/+0,26	40	18,3	12	203 KRR
KKR 06 B-1 21T	3/8" x 7/32"	68,0	63,91	7	16 +0,13/+0,26	40	18,3	12	203 KRR
KKR 081 B-1 18T	1/2" x 1/8"	78,9	73,14	7	16 +0,13/+0,26	40	18,3	12	203 KRR
KKR 083 B-1 16T	1/2" x 3/16"	70,9	65,10	7	16 +0,13/+0,26	40	18,3	12	203 KRR
KKR 083 B-1 18T	1/2" x 3/16"	78,9	73,14	7	16 +0,13/+0,26	40	18,3	12	203 KRR
KKR 08 B-1 14T	1/2" x 5/16"	61,8	57,07	7,2	16 +0,13/+0,26	40	18,3	12	203 KRR
KKR 08 B-1 15T	1/2" x 5/16"	65,5	61,09	7,2	16 +0,13/+0,26	40	18,3	12	203 KRR
KKR 08 B-1 16T	1/2" x 5/16"	69,5	65,10	7,2	16 +0,13/+0,26	40	18,3	12	203 KRR
KKR 08 B-1 18T	1/2" x 5/16"	77,8	73,14	7,2	16 +0,13/+0,26	40	18,3	12	203 KRR
KKR 08 B-1 20T	1/2" x 5/16"	85,8	81,19	7,2	16 +0,13/+0,26	40	18,3	12	203 KRR
KKR 08 B-1 21T	1/2" x 5/16"	89,7	85,22	7,2	16 +0,13/+0,26	40	18,3	12	203 KRR
KKR 10 B-1 13T	5/8" x 3/8"	73,0	66,32	9,1	16 +0,13/+0,26	40	18,3	12	203 KRR
KKR 10 B-1 14T	5/8" x 3/8"	78,0	71,34	9,1	16 +0,13/+0,26	40	18,3	12	203 KRR
KKR 10 B-1 15T	5/8" x 3/8"	83,0	76,36	9,1	16 +0,13/+0,26	40	18,3	12	203 KRR
KKR 10 B-1 16T	5/8" x 3/8"	88,0	81,37	9,1	16 +0,13/+0,26	40	18,3	12	203 KRR
KKR 10 B-1 17T	5/8" x 3/8"	93,0	86,30	9,1	16 +0,13/+0,26	40	18,3	12	203 KRR
KKR 10 B-1 18T	5/8" x 3/8"	98,3	91,42	9,1	16 +0,13/+0,26	40	18,3	12	203 KRR
KKR 10 B-1 21T	5/8" x 3/8"	113,4	106,52	9,1	16 +0,13/+0,26	40	18,3	12	203 KRR
KKR 12 B-1 12T	3/4" x 7/16"	81,5	73,60	11,1	16 +0,13/+0,26	40	18,3	12	203 KRR
KKR 12 B-1 13T	3/4" x 7/16"	87,5	79,59	11,1	16 +0,13/+0,26	40	18,3	12	203 KRR
KKR 12 B-1 15T	3/4" x 7/16"	99,8	91,63	11,1	16 +0,13/+0,26	40	18,3	12	203 KRR
KKR 12 B-1 16T	3/4" x 7/16"	105,5	97,65	11,1	16 +0,13/+0,26	40	18,3	12	203 KRR
KKR 16 B-1 12T	1" x 17,02 mm	109,0	98,14	16,1	20 +0,1/+0	47	17,7	14	204 KKR
KKR 16 B-1 15T	1" x 17,02 mm	133,0	122,17	16,2	20 +0,1/+0	47	17,7	14	204 KKR
KKR 16 B-1 17T	1" x 17,02 mm	149,0	138,24	16,2	20 +0,1/+0	47	17,7	14	204 KKR
KKR 20 B-1 13T	1"1/4 x 3/4"	147,8	132,65	18,5	25 +0,1/+0	52	21,0	15	205 KKR