

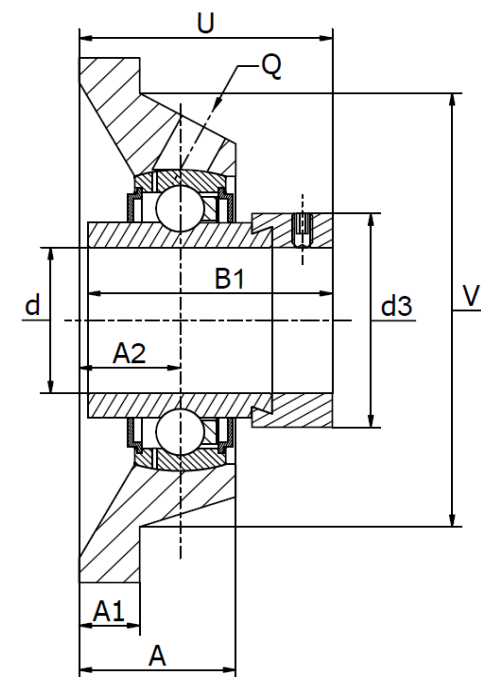

## FWS .. L Series (LCJ)

Four-bolt flanged housing units, cast iron, eccentric locking collar, low friction seals, -40 to +180°C.

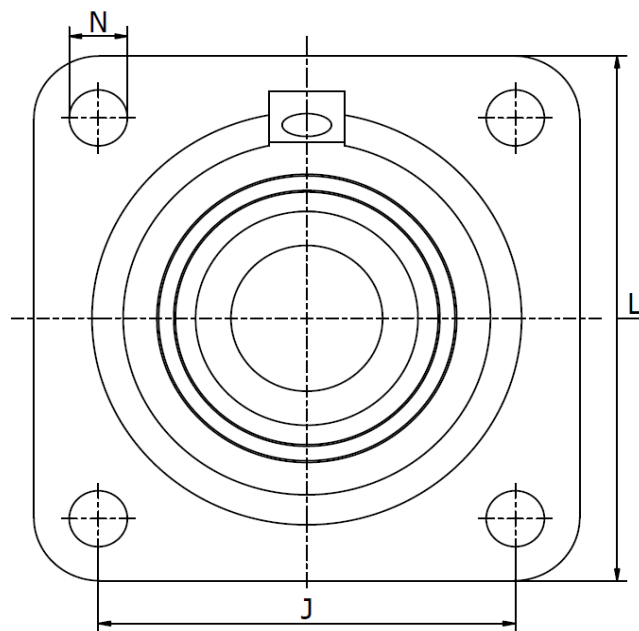

Type	d mm	Dimensions (mm)											Bearing No.	Housing No.	Weight (kg)	Cover (Not included)
		L	U	A	A <sub>1</sub>	A <sub>2</sub>	B <sub>1</sub>	d <sub>3 max</sub>	J	N	Q	V				
FWS 20 L - LCJ20	20	86	45,6	29,0	10,0	19,0	43,7	33,0	63,5	11,5	1/8"	68	HC 204 L091	CJ04	0,65	N/A
FWS 25 L - LCJ25	25	95	46,0	29,0	11,0	19,0	44,4	37,5	70,0	11,5	1/8"	74	HC 205 L091	CJ05	0,82	KASK05
FWS 30 L - LCJ30	30	108	50,2	29,0	12,0	20,0	48,4	44,0	82,5	11,5	1/8"	85	HC 206 L091	CJ06	1,16	KASK06
FWS 35 L - LCJ35	35	118	53,5	30,5	12,5	21,0	51,1	51,0	92,0	14,0	1/8"	100	HC 207 L091	CJ07	1,47	Cover Ø35
FWS 40 L - LCJ40	40	130	59,1	34,5	13,0	24,0	56,3	60,3	101,5	14,0	1/8"	110	HC 208 L091	CJ08	2,02	KASK08
FWS 45 L - LCJ45	45	137	59,1	35,0	13,0	24,0	56,3	63,0	105,0	14,0	1/8"	116	HC 209 L091	CJ09	2,26	Cover Ø40/45
FWS 50 L - LCJ50	50	143	66,1	39,0	13,0	28,0	62,7	69,0	111,0	18,0	1/8"	125	HC 210 L091	CJ10	2,53	KASK10