

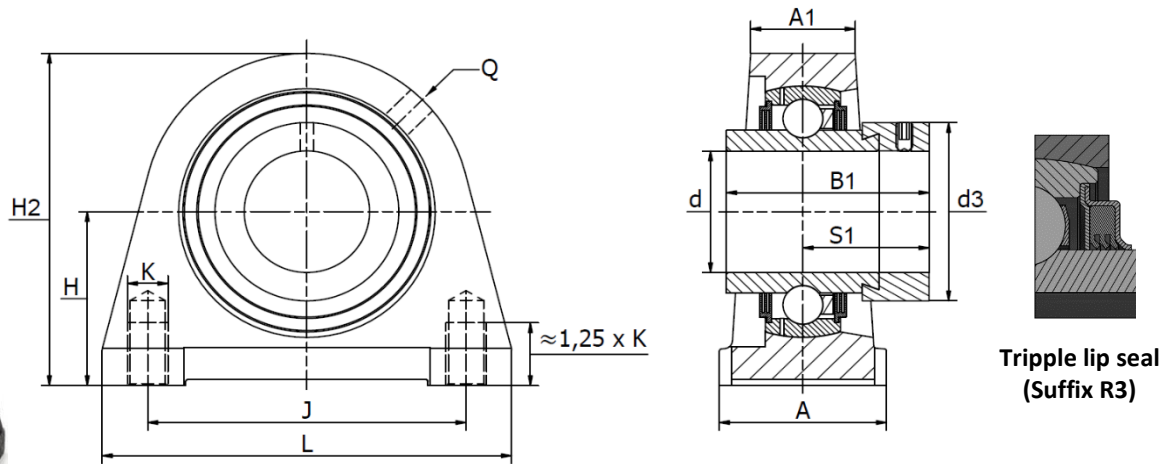

## SWG .. T Series (TSHE)

Cast iron housing, radial insert ball bearing with eccentric locking collar, triple seals.

Temperature range -30°C to +110°C



Tripple lip seal  
(Suffix R3)

Part No.	d mm	Dimensions (mm)											Bearing No.	Weight (kg)
		L	H <sub>2</sub>	A	A <sub>1</sub>	B <sub>1</sub>	d <sub>3 max</sub>	H	J	K	Q	S <sub>1</sub>		
SWG 20 T	20	65	64,0	32	19	43,7	33,0	33,3	50,8	M8	M6	26,6	HC 204 R3	0,55
SWG 25 T	25	70	70,0	36	21	44,4	37,5	36,5	50,8	M10	Rp 1/8"	26,9	HC 205 R3	0,66
SWG 30 T	30	98	82,0	40	25	48,4	44,0	42,9	76,2	M10	Rp 1/8"	30,1	HC 206 R3	1,12
SWG 35 T	35	103	93,0	45	27	51,1	51,0	47,6	82,6	M10	Rp 1/8"	32,3	HC 207 R3	1,51
SWG 40 T	40	116	99,0	48	30	56,3	58,0	49,2	88,9	M12	Rp 1/8"	34,9	HC 208 R3	1,96
SWG 45 T	45	120	107,0	48	32	56,3	63,0	54,0	95,3	M12	Rp 1/8"	34,9	HC 209 R3	2,26
SWG 45 T	45	120	107,0	54	32	56,3	63,0	54,0	95,3	M12	Rp 1/8"	34,9	HC 209 R3	2,26
SWG 50 T	50	135	115,0	54	34	62,7	69,0	57,2	101,6	M16	Rp 1/8"	38,1	HC 210 R3	3,02
SWG 55 T	55	150	124,5	60	35	71,4	76,0	63,5	118,0	M16	Rp 1/8"	43,6	HC 211 R3	3,52
SWG 60 T	60	150	140,0	60	42	77,8	84,0	69,9	118,0	M16	Rp 1/8"	46,8	HC 212 R3	4,54