

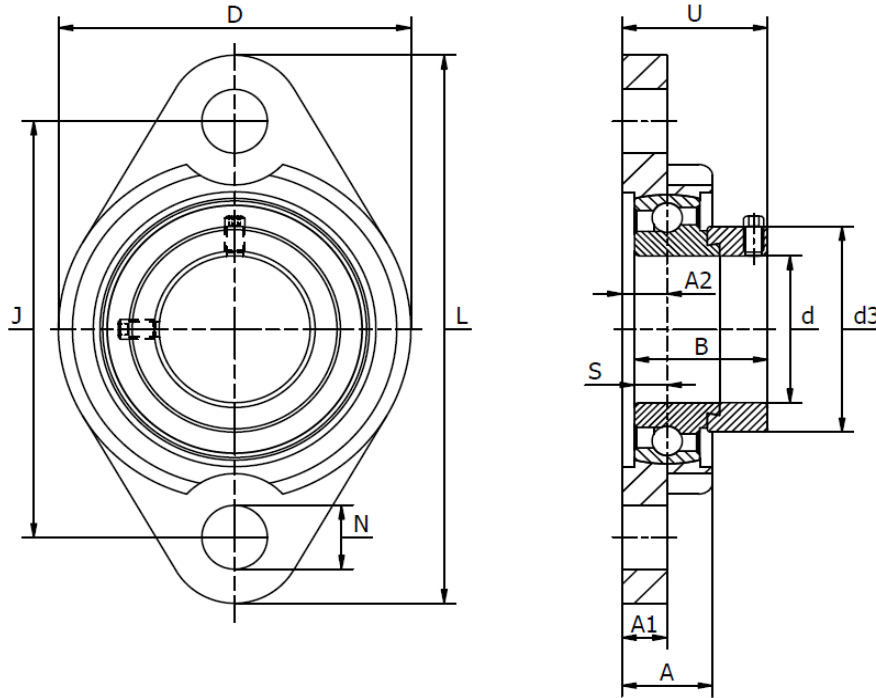

## UFL 000 - 2-Bolt Flanged Housing Series

Silver Series, rustproof zinc aluminium housing, high carbon chromium bearings, eccentric locking collar, solid base.



Part no.	d mm	Dimensions (mm)										Mounting bolt	Weight (g)	Temperature	
		L	J	A2	A1	A	S	D	U	B	S				
UFL 000	10	60	45	5,5	5,5	11,5	7	36	19,0	17,5	4,0	17,0	M6	100	-10°C to +80°C
UFL 001	12	63	48	5,5	5,5	11,5	7	38	19,0	17,5	4,0	19,0	M6	100	-10°C to +80°C
UFL 002	15	67	53	6,5	6,5	13,0	7	42	20,5	18,5	4,5	22,0	M6	100	-10°C to +80°C
UFL 003	17	71	56	7,0	7,0	14,0	7	46	22,5	20,5	5,0	25,0	M6	200	-10°C to +80°C
UFL 004	20	90	71	8,0	8,0	16,0	10	55	26,5	24,5	6,0	30,0	M8	200	-10°C to +80°C
UFL 005	25	95	75	8,0	8,0	16,0	10	60	27,5	25,5	6,0	36,0	M8	200	-10°C to +80°C
UFL 006	30	112	85	9,0	9,0	18,0	13	70	29,0	26,5	6,5	42,0	M10	300	-10°C to +80°C
UFL 007	35	122	95	10,0	10,0	20,0	13	80	32,5	29,5	7,0	48,0	M10	500	-10°C to +80°C