

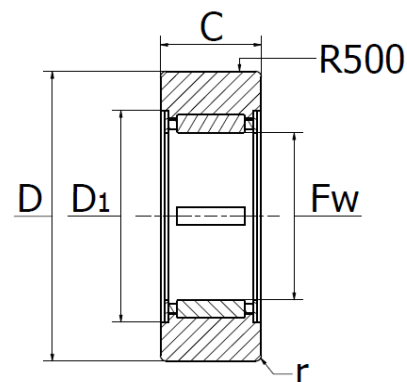

RNA - Yoke Type Track Rollers

Without axial guidance. Lip seals on both sides, curved outer race



Part No.	Dimensions (mm)						Mass g	Load rating(N)			nDG (1/min)
	Fw	D	C	D1min	R	rmin		Crw	C0rw	Curw	
RNA22-6.2RS	10	19	11,8	15,15	500	0,3	18	3900	3700	495	9000
RNA22-8.2RS	12	24	11,8	18	500	0,3	29	4800	4300	650	7000
RNA2200.2RS	14	30	13,8	20	500	0,6	52	7000	6900	1120	5500
RNA2201.2RS	16	32	13,8	22	500	0,6	57	7500	8300	1290	4700
RNA2202.2RS	20	35	13,8	26	500	0,6	60	7600	9900	1390	3400
RNA2203.2RS	22	40	15,8	28	500	1,0	94	9900	14200	1870	3000
RNA2204.2RS	25	47	17,8	33	500	1,0	152	14000	19300	2700	2300
RNA2205.2RS	30	52	17,8	38	500	1,0	179	14400	21100	2950	1800
RNA2206.2RS	35	62	19,8	43	500	1,0	284	17000	26500	3600	1400
RNA2207.2RS	42	72	22,7	50	500	1,1	432	21500	36500	5300	1100
RNA2208.2RS	48	80	22,7	57	500	1,1	530	26000	41500	5400	850

Legend:

- Fw** Needle roller enveloping circle in tolerance zone F6
- R** Crowning radius
- Crw** Effective dynamic load rating as track roller (radial)
- C0rw** Effective static load rating as track roller (radial)
- Curw** Fatigue limit load
- nDG** Speed (with continuous operation and grease lubrication)